

A BATTERY-OPERATED PORTABLE STANDARD LEAD ECG MONITOR WITH ABNORMAL HEART CONDITION DETECTION SYSTEM FOR DOGS

by

Zichen He

A Thesis Submitted in
Partial Fulfillment of the
Requirements for the Degree of

Master of Science

in Engineering

at

The University of Wisconsin-Milwaukee

August 2017

ABSTRACT

A BATTERY-OPERATED PORTABLE STANDARD LEAD ECG MONITOR WITH ABNORMAL HEART CONDITION DETECTION SYSTEM FOR DOGS

by

Zichen He

The University of Wisconsin-Milwaukee, 2017
Under the Supervision of Professor Devendra Misra

Long term monitoring the dog's heart condition is the best way to prevent being unable to treat the dog's heart failure in time when it occurs. Although, electro-cardio activity has been discovered by French scientist Mattencci in 1842, but there hasn't been any proper device developed so far for long term ECG (electrocardiogram) monitoring of cardiac dogs. Therefore, this paper has proposed an ECG monitor specially designed for dogs to fill this gap. The ECG monitor proposed is a 3-lead ECG monitoring system with diagnosis software that can detect heart failure, tachycardia, bradycardia, and arrhythmia according to dog's ECG signal. It mainly consists of 3 active dry electrodes that acquire dog's ECG signal; an analog front-end circuit that amplifies and filters the acquired signal; and a processor that further filters and analyzes the signal, and then it will determine if the dog is having an abnormal heart condition; finally, all results is displayed on a LCD (liquid crystal display).

key words: ECG, heart failure, dog, veterinary, cardiac

To
my parents,
my ex-girlfriend,
and especially my ex-girlfriend's cardiac dog

TABLE OF CONTENTS

Chapter	Page
ABSTRACT	ii
TABLE OF CONTENTS.....	iv
LIST OF FIGURES.....	vii
LIST OF TABLES	vvi
ACKNOWLEDGMENTS	viii
CHAPTER I: Introduction.....	1
1.1 Purpose of My Research	1
1.2 Introduction to Generation of ECG.....	1
1.3 Dog's ECG Diagnosis	4
1.3.1 Influences on dog's ECG	4
1.3.2 A brief introduction to 4 heart conditions	4
CHAPTER II: Background and Literature Review.....	6
2.1 Two Technology Trends for Human ECG Monitor	6
2.1.1 Professional medical trend	6
2.1.2 Public healthcare trend	6
2.2 Current ECG Monitors for Dogs.....	7
CHAPTER III: System Design	10
3.1 Hardware Design	10
3.1.1 Electrodes	10
3.1.2 Front-end amplification circuit	12
3.1.3 Signal processor and diagnosis display	12

3.2 Software Design	13
3.2.1 Digital filter	13
3.2.2 Algorithm of HR calculation	14
3.2.3 Diagnosis functions	15
CHAPTER IV: Test Results and Analysis	17
4.1 Front-end Circuit Test	17
4.2 System Field Test	17
CHAPTER V: Conclusion.....	21
REFERENCES.....	22
Appendix A	23
Appendix B	24
Appendix C	25

LIST OF FIGURES

Figure	Page
Figure 1.1: the electricity generated by cardiomyocytes' contraction.	2
Figure 1.2: electric and mechanical activity of a cardiomyocyte.	2
Figure 1.3: the relationship between ECG waveform and heartbeat.	3
Figure 1.4: the longest time between R-R wave is at least 0.16s longer than the shortest, then its diagnosed to have arrhythmia.	5
Figure 2.1: (a) professional ECG monitor; (b) implementation of 12-lead monitor.	6
Figure 2.2: (a) Holter monitor; (b) ECG smart shirt; (c) FDA approved smart phone based phone case - Kardia Mobile ECG; (d) Apple Watch based Kardia Band.	7
Figure 2.3: dog wearing a Holter monitor	8
Figure 2.4: (a) AliveCor's iPhone based Veterinary Heart Monitor; (b) measuring a dog's ECG with AliveCor's Veterinary Heart Monitor.	9
Figure 3.1: basic schematics of an active dry electrode.	11
Figure 3.2: the prototype used self-made active dry electrodes.	11
Figure 3.3: C8051F410 Dog 5mum system development board.	13
Figure 3.4: 2nd-order IIR notch filter with a stop band between 59.5Hz to 60.5Hz.	14
Figure 3.5: the algorithm of computing HR.	15
Figure 3.6: (a) normal heart condition; (b) AT: arrhythmia warning; (c) TC: tachycardia warning; (d) BC: bradycardia warning; (e) HF: heart failure warning; (f) Etro Dtch: electrodes not attached warning.	16
Figure 4.1: (a) human ECG recorded with simple dry electrodes; (b) human ECG recorded with active dry electrodes has less noise.	17
Figure 4.2: electrodes placement.	18

LIST OF TABLES

Table	Page
Table 1: Heart rates of the 5 dogs.....	19
Table 2: Strength of heartbeats of the 5 dogs	20

ACKNOWLEDGMENTS

First, I want to thank my academic advisor, Professor Devendra Misra, for his overall guidance in my thesis project and advice on my front-end circuit design, and most importantly, it was him who encouraged me to do research in my own area of interest, which is ECG monitoring. I would also like to thank my ex-girlfriend. Because of her, I realized that there hasn't been enough veterinary medical device developed for pets, which helped me later found that there hasn't been any portable long-term ECG monitor developed for dogs.

I thank Professor David McClanahan for allowing me to have access to the lab, and all the materials and equipments in it, so I could work on my circuit whenever I could. And a great thanks to my beloved bike, it carried me for 2 years without any maintenance or breaking apart.

Last but not least, I'd like to give my thanks to the dogs and the dog owners who agreed to provide me their lovely dogs' ECG data that is collected by my designed monitor.

CHAPTER I: Introduction

1.1 Purpose of My Research

Dogs have been a part of human civilization since the Ice Age, they play an important role in the human society. For example, 36.5% of households own dogs in the US, and every year, there are averagely 2.6 veterinary visits for each household (1). Moreover, about 9 out of 10 Americans say they consider their pets to be a part of their family, and they care about their dogs' welfare. But, like any family member, dogs grow old as well, and sure they start to have heart diseases like any other old people. Considering dogs can't tell us that they feel sick, and it is crucial for a dog owner to be aware as soon as possible that his or her dog is having an abnormal heart condition, or worse, a heart attack. Therefore, monitoring the dog's heart condition is the best way to prevent being unable to treat the dog's heart failure in time when it occurs. Mattencci, a French scientist, had discovered electro-cardio activity ever since in 1842, however, there hasn't been any proper device developed so far for long term ECG monitoring of cardiac dogs. And that is why I propose this ECG monitor specially designed for dogs to fill this gap.

1.2 Introduction to Generation of ECG

Heart beats because of cardiomyocytes' (heart muscle cell) contraction. As one of the excitable cells, every single cardiomyocyte's contraction is mediated by neural electricity as the same mechanism as neurons (2) - for each cardiomyocyte, before contraction begins, intracellular chloridions provide a negative electric potential on the inner surface of the membrane; and extracellular sodions provide a positive potential on the outer surface. The ions on both sides of the cardiomyocyte's membrane approximately generate a voltage of -70mV, which is called resting potential. Right before the contraction begins, resting potential will switch to action potential by opening the voltage-gated ion channels on its membrane, and letting extracellular

sodiums flow inside of the cell, and intracellular chloridions flow outside of it, as shown in Fig 1.1. The flow of ions shifts the potential on the membrane and generates a electric current, this process is called depolarization.

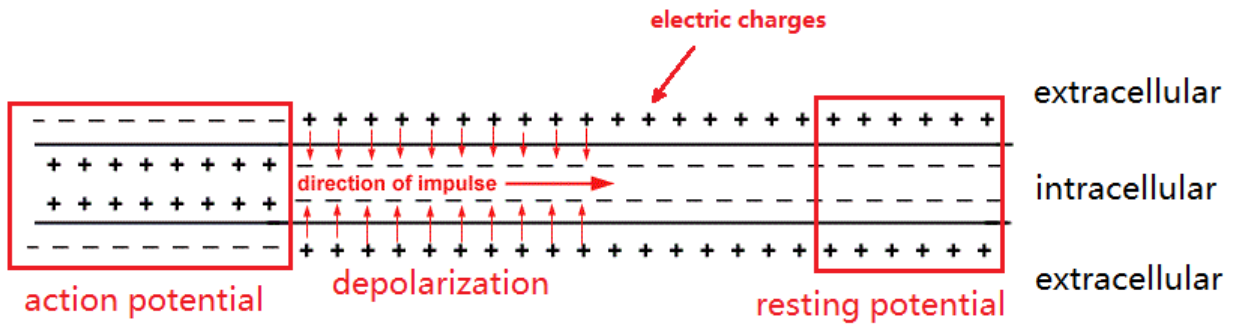

Figure 1.1: the electricity generated by cardiomyocytes' contraction.

Afterwards, repolarization sets the membrane potential back to resting potential with an outflow of intracellular potassium ions (3). Fig 1.2 shows a complete electric and mechanical activity of a cardiomyocyte (2).

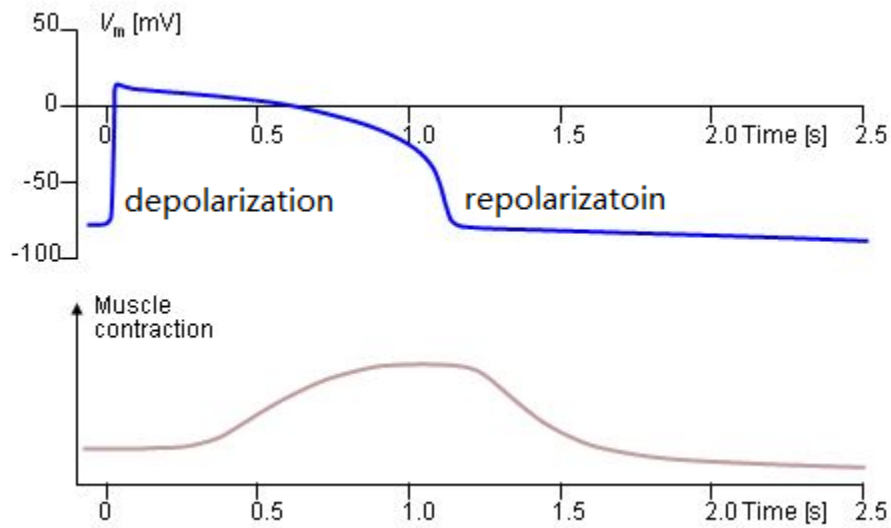

Figure 1.2: electric and mechanical activity of a cardiomyocyte.
This figure is from (3) Bioelectromagnetism, 1995

For a whole heartbeat process, depolarization occurs first at the sinus node on the right atrium of the heart and then goes to both atria, inducing heart contraction. The voltage generated

during this process is P wave in an ECG; after about a 100ms-delay, atria contraction is over, and depolarization wave emits to atrioventricular (AV) node, causing contraction in both ventricles, meantime, atria repolarize and relax. The voltage generated during this process is QRS complex (waves) in an ECG. Thereafter, ventricles repolarize and relax, generating T wave in an ECG. After T wave, there is the U wave. As the last identifiable part in an ECG, U wave, in some cases, could be too small to see. The representation of U wave in an ECG is unknown, but it is commonly believed to be repolarization of Purkinje fibers in the heart. And that is a complete cycle of a heartbeat (2), as shown in Fig 1.3.

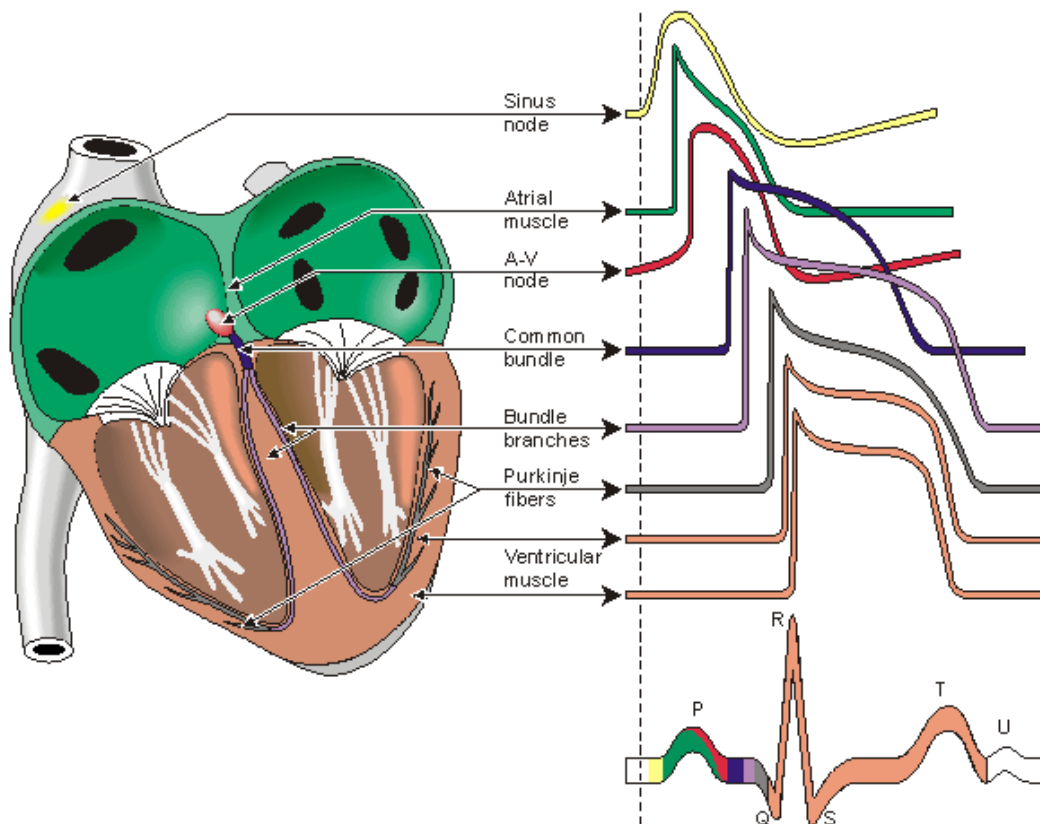

Figure 1.3: the relationship between ECG waveform and heartbeat.
This figure is from (3) Bioelectromagnetism, 1995

1.3 Dog's ECG Diagnosis

1.3.1 Influences on dog's ECG

First of all, different from human heart rate, dogs have different heart rate ranges depending on their sizes. For small sized dogs and puppies, their heart rate range is relatively higher and it's commonly between 80bpm to 160bpm. In some cases, such as new born puppies, their heart rate could be over 200bpm. And for both medium sized dogs and large sized dogs, their heart rate is commonly between 60bpm to 100bpm, just like human heart rate (4).

A special feature about dog's heart rate is that even when a dog is relaxed and still, its heart rate could still be irregular due to dog's very physiology - the heart rate could have a periodical increase or decrease due to dog's vagus nerve activity in respiration (breathing activity) (4). This usually normal heart condition is called sinus arrhythmia, which is more common among dogs than human. Also, dog's ECG differs from gender and age. For example, for a same breed, the length of P wave detected from female's ECG is usually longer than male's (4). And young dogs' heart rate is higher than adult dogs'.

1.3.2 A brief introduction to 4 heart conditions

1. Heart failure. Heart failure is not a disease, but a final stage of heart diseases. It is caused by systolic or (and) diastolic dysfunction, meaning that the heart becomes unable to pump out all venous blood, resulting a lack of blood in arterial system, which means a lack of O₂ for the body and potential thrombus. A common early symptom of heart failure is dyspnea (breath with difficulty). For acute heart failure, also known as heart attack, its early symptom in ECG is tachycardia (an increase in heart rate) and a decrease in amplitude of QRS complex, that is, a decrease in strength of heart beat.

2. Tachycardia. Heart rate being above normal range is called tachycardia. It is often a normal response to physical stress, for example, strenuous exercise, but also might be a symptom of heart failure (2).

3. Bradycardia. Heart rate being below normal range is called bradycardia. It's usually not a big issue, it could be found during athletes' and old people's sleep.

4. Arrhythmia. Arrhythmia means an irregular heart rate, which is a common situation in all age groups (2). As mentioned in section 1.3.1, one of the causes is vagus nerve activity in respiration, specifically, vagus nerve mediates respiration, effecting sinus node, which causes an increase of heart rate during inspiration (breathing in) and a decrease of heart rate during expiration (breathing out). In ECG, if the longest time between 2 nearby P waves or R waves is at least 0.16s longer than the shortest, then the heart is diagnosed to have arrhythmia, as shown in Fig.1.4.

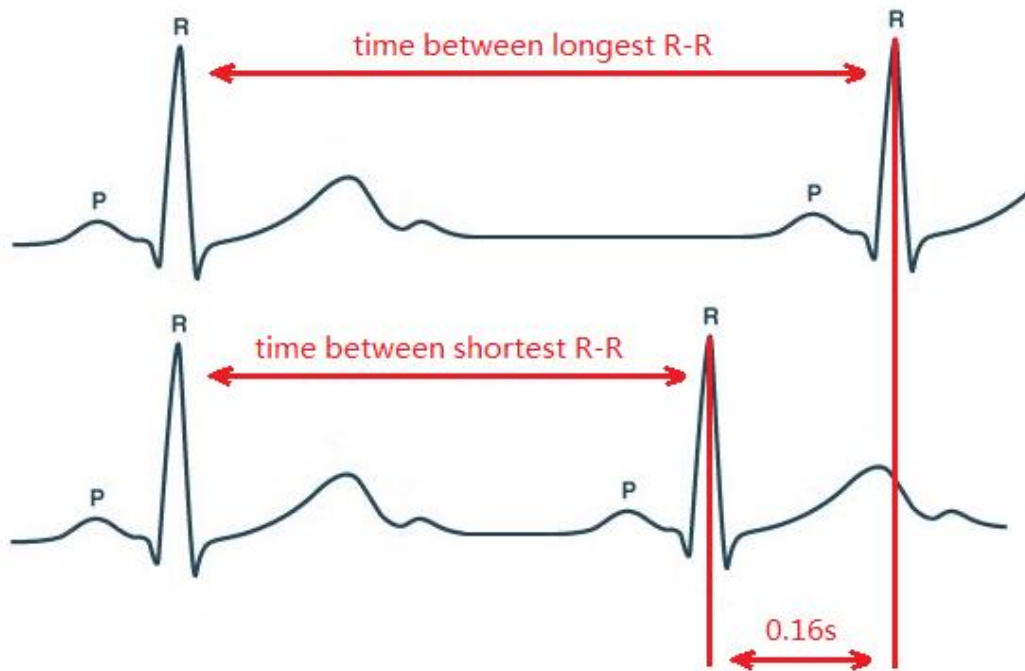

Figure 1.4: the longest time between R-R wave is at least 0.16s longer than the shortest, then its diagnosed to have arrhythmia.

CHAPTER II: Background and Literature Review

2.1 Two Technology Trends for Human ECG Monitor

2.1.1 Professional medical trend

Heart diseases are diagnosed by examining the waveforms of ECG. For medical personnel, they always want a more accurate and precise ECG monitor for better diagnosis. So, ECG monitors developed under this trend focus on accuracy and precision. To achieve a comprehensive examination of ECG, a standard lead ECG monitor (using 3 electrodes) has become incapable of the job, therefore, 12-lead ECG monitors (using 10 electrodes) have been developed to record every stage of a heartbeat, providing more detailed information about P-QRS-T waves. However, as its disadvantage, these professional devices tend to be big in size, not portable, and relatively complex to use, as shown in Fig. 2.1.



Figure 2.1: (a) professional ECG monitor; (b) implementation of a 12-lead ECG monitor.

2.1.2 Public healthcare trend

For public healthcare, the popular goal is "doing it at home". Therefore, medical devices for public healthcare are designed to be small and light weighted, easy to use, wireless (5), and low power consumption, also, as a consequence of convenience, ECG monitors under this trend are usually less accurate and precise than the professional ones due to the pursuance of using only 2 electrodes (6). As the advantage, ECG monitors for everyday healthcare are usually either

wearable or portable, which means they are small sized, light weighted, and maybe even integrated in something else. They often have low or even ultra-low power consumption (7), which makes it possible to operate on battery for long term monitoring. For example, there is Holter Monitor series; AliveCor's smart phone based 2-electrode phone case - Kardia Mobile ECG, which has been approved by FDA; ECG smart shirt; and AliveCor's Apple Watch based Kardia Band that uses the watch's own microphone to receive ECG data, as shown in Fig. 2.2.

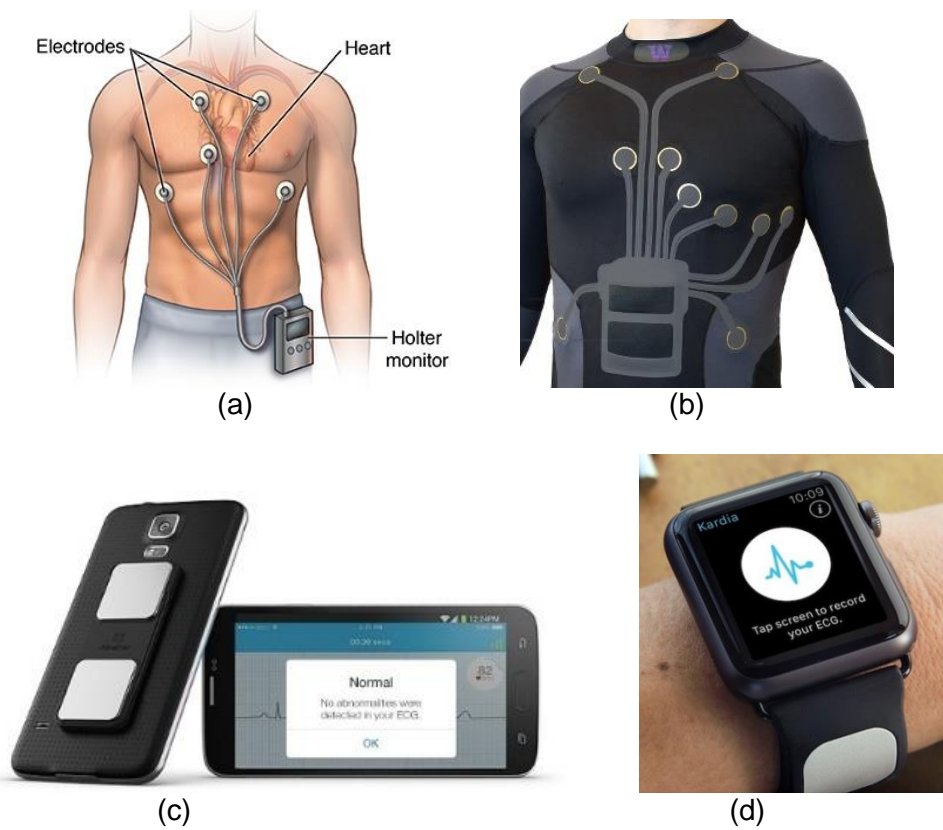

Figure 2.2: (a) Holter monitor; (b) ECG smart shirt; (c) FDA approved smart phone based phone case - Kardia Mobile ECG; (d) Apple Watch based Kardia Band.

2.2 Current ECG Monitors for Dogs

ECG monitoring has already been a mature technique. There have been articles about study of dog's ECG, but, surprisingly, no literature has been found so far about ECG monitors designed for dogs. Currently, professional ECG monitors used in veterinary hospitals and clinics are basically as good as ones for human. However, there is a lack of portable veterinary ECG

monitor for dog's everyday healthcare. No relative literature has been found about ECG monitor specially designed for dogs, the only 2 monitors on the market that are found to be related to portable veterinary ECG monitor are Holter monitor and AliveCor's iPhone based Veterinary Heart Monitor. A Holter monitor is a portable monitor operates on batteries, it can continuously measures and records ECG for more than 24 hours. Although, Holter monitor can be used on pets like dogs, it is originally designed for human use. As a consequence, for dog's long-term monitoring, a dog has to wear a jacket so that it can carry the small camera-sized Holter monitor with it, as shown in Fig 2.3.



Figure 2.3: dog wearing a Holter monitor.

Similar to Kardia Mobile ECG, Veterinary Heart Monitor designed by AliveCor is an iPhone based mobile ECG recorder. It, too, has 2 dry electrodes integrated in the phone case, as shown in Fig. 2.4. By simply attaching the electrodes to animal's body, the electronics in the phone case will collect ECG data and transmit it to the signal processor - iPhone; the corresponding app in the iPhone will display and store the animal's ECG.



(a)



(b)

Figure 2.4: (a) AliveCor's iPhone based Veterinary Heart Monitor; (b) measuring a dog's ECG with AliveCor's Veterinary Heart Monitor.

For Holter monitor and Veterinary Heart Monitor, what they have in common is that they both are portable, and they can record and store dog's ECG. But the problems are: Holter monitor is not very convenient, and maybe even uncomfortable for a dog, because it's not designed for dogs. And Veterinary Heart Monitor is not wearable, and not good enough for long-term monitoring, depending on the design of it. Moreover, in practical situations, both of these two devices can only record ECG, they are unable to diagnose any abnormal heart conditions. However, most people are not doctors, they can't tell how their dogs' hearts are doing by simply reading the ECG recording; and on the other hand, for veterinary personnel, they wouldn't make a diagnosis based on those less professional ECG recordings, instead, they would ask the cardiac dogs to have their ECG recorded with hospital's own ECG monitors. In this case, displaying and recording ECG seems to be unnecessary, on the contrary, what's really needed is that the monitor notifying the dog owner about his or her cardiac dog's abnormal heart condition in time, so that the dog could receive medical treatment in time - and this is the achieved purpose of the prototype of this proposed monitor.

CHAPTER III: System Design

3.1 Hardware Design

3.1.1 Electrodes

There are 2 types electrodes, one is wet electrode, the other is dry electrode. Wet electrode is known to have the advantage of low motion artifact. Its conductive adhesive gel makes the electrode possible to tightly attach to skin as well as create a conductive path between skin and electrode, which can greatly reduce motion artifact created at electrode-skin interface. However, unlike dry electrode, employment of wet electrode would be limited in some situations due to its preparation, placement, and disposable one-time-use characteristics. In this case, dog's furry skin makes wet electrode's conductive gel pointless. Also, considering that wet electrode is not suitable for long-term daily use, consequently, dry electrode is a better option for this dog's ECG monitor due to its advantage in convenience and long-term monitoring. However, without help of adhesive gel, it's hard to have no relative movement at all between dry electrode and skin, meaning that it's more likely to cause motion artifact in ECG. And without conductive path between electrode and skin that is provided by wet gel, high contact impedance at electrode-skin interface is another cause of high motion artifact.

Therefore, the best solution for electrode of dog's ECG monitor is active dry electrode (6). Active dry electrode basically consists of a simple dry electrode and a voltage follower, as shown in Fig. 3.1. The voltage follower provides a unity gain buffer to reduce dry electrode's high contact impedance by converting it to low impedance at the output of the voltage follower.

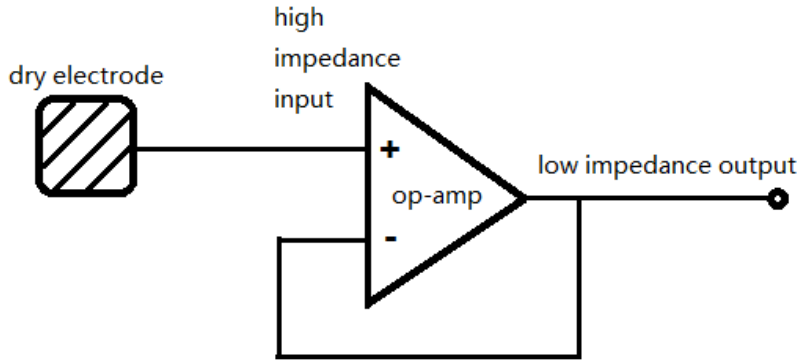

Figure 3.1: basic schematics of an active dry electrode.

As a consequence of no suitable active dry electrode was found available for purchase, the active dry electrodes for the prototype of this proposed design is built with OP07CP operational amplifiers and simple dry electrodes, as shown in Fig. 3.2.

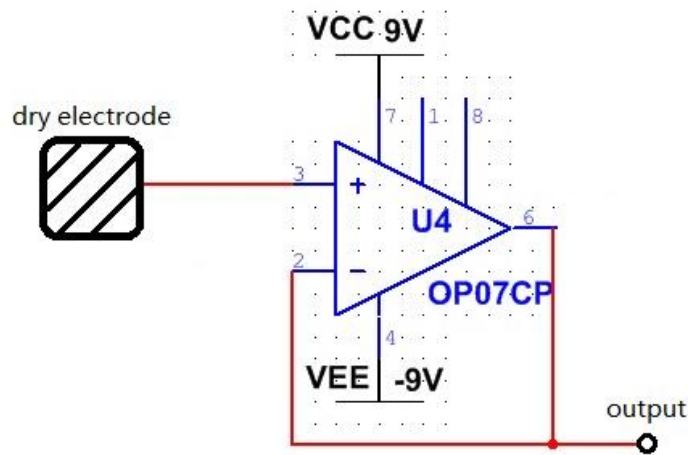

Figure 3.2: the prototype used self-made active dry electrodes.

For a standard lead ECG monitor, 3 active dry electrodes (LA, RA, and RL) is employed. To reduce baseline drift caused by respiration and other noises, instead of placing them on dog's body, LA is placed on left front leg of the dog, RA is placed on right front leg, and RL is on right rear leg.

3.1.2 Front-end amplification circuit

ECG signal acquired through active dry electrodes from the body will be amplified before it goes to ADC (analog to digital converter). As shown below in Appendix A, the schematics of front-end circuit design, ECG signal collected from active dry electrodes LA and RA is first sent to a low power high accuracy instrumental amplifier AD620AN that has a high common mode signal rejection ratio (CMRR=93dB). AD620AN will provide the ECG signal a low gain of 9.2. The instrumental amplifier will amplify differential mode signal, which is ECG signal, while undesired common mode signal in the ECG is canceled by the amplifier. The output of AD620AN will go through a high pass filter with a cut-off frequency of 0.03Hz that will eliminate DC offset and other very low frequency noise components such as baseline drift. After the high pass filter, ECG signal will be amplified as well as filtered by a second order low pass filter built with a high accuracy operational amplifier OP07CP. The frequency range of ECG is 0~100Hz, but most ECG energy are concentrated within 3~40Hz range (8), therefore, to filter out the periodical noise caused by 110V 60Hz AC powerline, the cut-off frequency is set to 49.7Hz. Also, the gain is set to 130, which will provide an overall gain of 1197 to amplify the ECG signal around 0.4mV to 500mV for ADC. All in all, the front-end circuit provides a total gain of 1197, and 2 cascaded filters with a pass band between 0.03Hz to 49.7Hz. The device is made portable by powering the circuit with two 9V batteries that provide a $\pm 9V$ for all the amplifiers.

3.1.3 Signal processor and diagnosis display

A C8051F410 Dog 5mum system development board is used as the signal processor, as shown in Fig.3.3. The processed analog ECG signal coming from front-end circuit will be received and converted into digital signal by an 12-bit AD converter module integrated in C8051F410. The reference voltage of AD converter is 2.2V. According to the 500Hz sample frequency recommendation (9)(10) from AHA (American Heart Association), the sample frequency for this device is set to 2000Hz to avoid aliasing artifact.

Thereafter, digitized ECG signal will first be processed by a 2nd-order Butterworth IIR notch filter, and then heart rate (HR) and the maximum amplitude of each ECG (V_m) will be computed as the diagnosis factors. And finally, diagnosis function will display any detected abnormal heart conditions on LCD (liquid crystal display). The whole process will be discussed in detail in Section 3.2.

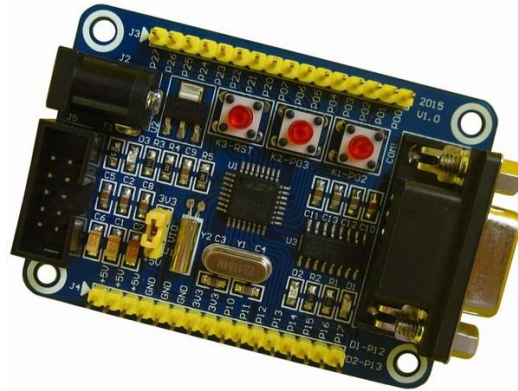

Figure 3.3: C8051F410 Dog 5µm system development board.

3.2 Software Design

3.2.1 Digital filter

Digitized ECG signal will first go through a 2nd-order IIR notch filter (11) with a stop band between 59.5Hz to 60.5Hz to further reduce the 60Hz noise acquired from powerline. It is designed to be Butterworth filter because of its characteristics of smoothest frequency response curve in the pass band, which will have least affect on ECG signal, as shown in Fig.3.4. Based on the coefficients generated by matlab, the filter equation [1] is shown below, where x is the current sample value of ADC result, x_1 and x_2 are latest previous values of ADC samples, and output y is filtered value of the current sample, y_1 and y_2 are latest previous values of filtered results. Each output of the filter will be used for computing HR and V_m .

$$y = 0.9969 * x - 1.9584 * x_1 + 0.9969 * x_2 + 1.9584 * y_1 - 0.9937 * y_2 \quad [1]$$

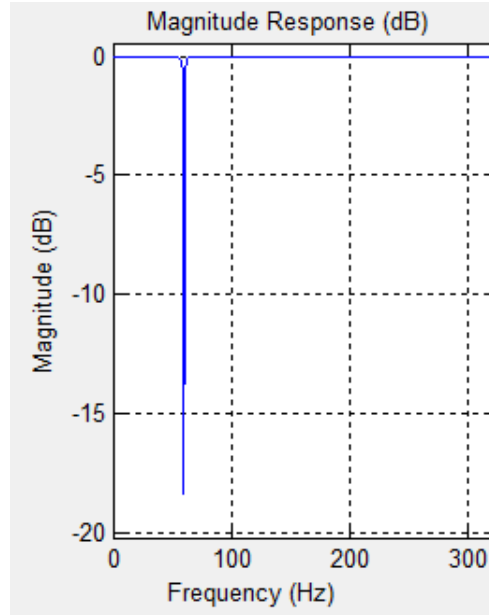

Figure 3.4: 2nd-order IIR notch filter with a stop band between 59.5Hz to 60.5Hz.

3.2.2 Algorithm of HR calculation

The diagnosis functions are based on HR and V_m . V_m is recorded by continuously updating the maximum value of the samples in each ECG waveform. A good way to calculate HR is to determine the time between R waves in the ECG, as determined by equation [2] below, where n stands for number of R waves, namely, the number of ECG waveforms, within the detection period, and t stands for the number of samples taken. The unit of HR is beats per minute (bpm), and f_s is the sample frequency of the device.

$$\frac{HR(\text{b/min})}{60s * f_s} = \frac{n - 1}{t} \quad [2]$$

In this case, HR is determined by the time of 2 ECG waveforms, therefore, n is set to 3. As described in Fig 3.5, the specific algorithm for measurement of n and t is: the binary variable "landmark" indicates whether the current sample value is above threshold, when it's above threshold, "landmark" goes from 0 to 1, whenever the current sample is below threshold, "landmark" will be set back to 0. "mark" is a variable with an initial value of 0 that will add "1" to itself whenever the current sample value is over threshold while "landmark" is 0, it is a counter

for keeping track of the number of waveforms passed. "Length" is a variable that keeps track of the number of samples, in other words, it records the time period between ECG waveforms. "length" starts counting when the current sample value is above threshold while "landmark" remains 0, because at that very point, the current sample is the first one passing the threshold, it is treated to be the starting point of an ECG waveform.

In this way, every starting point of each ECG waveform will be detected. And when "mark" becomes 3, which means the 2 waveforms has passed, and "length" has recorded the number of samples for 2 waveforms. Then "mark" will be reset back to 1 to start a new recording, and current value of "length" will be used to calculate HR, as t in equation [2], and n, as the number of waveforms, is 2.

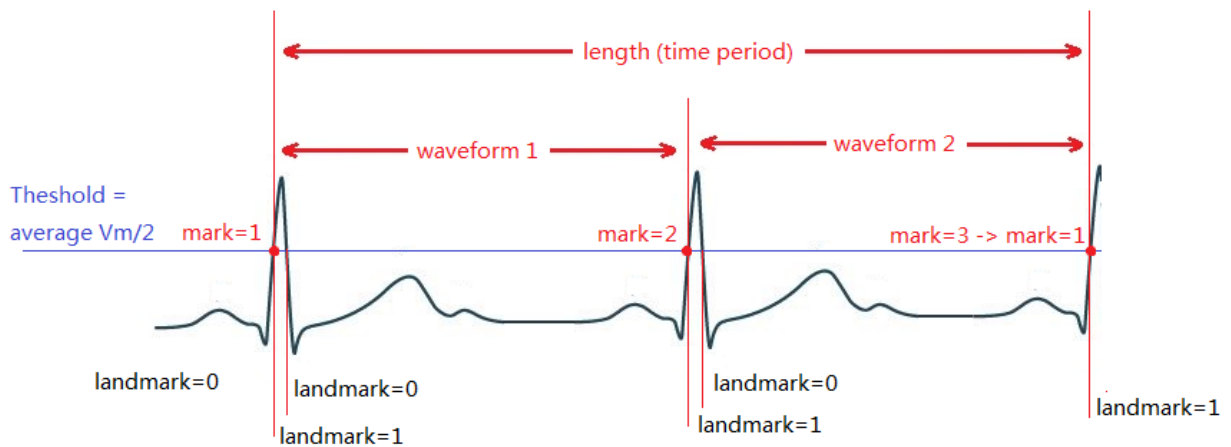

Figure 3.5: the algorithm of computing HR.

3.2.3 Diagnosis functions

First of all, there is a variable with an initial value of 0, called "alert", it is set to be a false alarm fail-safe. Once an abnormal heart condition is detected, it will not immediately display warning on the LCD screen, instead, "alert" will add 1 to itself, and whenever the heart condition is found to be normal again, "alert" will be set back to 0. However, once "alert" is accumulated to 5, which means the abnormal heart condition appears continuously, then the corresponding warning of abnormal heart condition will be displayed. The diagnosis functions are able to detect

detached electrodes as well as potential threats of tachycardia, bradycardia, arrhythmia, and most importantly, heart failure.

Based on what has been mentioned in section 1.3.2, it is defined in the diagnosis functions that if HR is over 140bpm, and Vm is bigger than 3/5 of the average Vm, then the dog is likely to be having tachycardia. If HR is below 60bpm, then the dog must has bradycardia that needs medical attention. And if HR is over 140bpm, while Vm is lower than 3/5 of the average Vm, then it's possible that the dog is having an early symptom of heart failure. To diagnose arrhythmia, there is a variable called "lengthmax", it's purpose is to keep track of the maximum time period of ECG waveforms. It is compared with each current time period of the ECG, if it frequently happens that "lengthmax" is 0.16s longer than the current record, then the dog is likely to have arrhythmia. And finally, if HR is 0, then a warning of "electrodes detached" will be displayed. Fig 3.6 shows the demo of all warnings displayed on LCD.



Figure 3.6: (a) normal heart condition; (b) AT: arrhythmia warning; (c) TC: tachycardia warning; (d) BC: bradycardia warning; (e) HF: heart failure warning; (f) Etro Dtch: electrodes not attached warning.

CHAPTER IV: Test Results and Analysis

4.1 Front-end Circuit Test

Fig.4.1 shows the results of the same human ECG amplified by this proposed front-end circuit using simple dry electrodes and active dry electrodes, displayed on an oscilloscope. The electrode LA was attached to the wrist of test subject's left arm, RA to the wrist of test subject's right arm, and RL to the wrist of test subject's right leg. During the test, the subject was sitting on a chair and remained still.

As shown in the Fig 4.1, the ECG recorded by active dry electrodes is less jaggy than the one without active dry electrodes. Therefore, it is obvious that active dry electrodes have successfully reduced the noise by lowering the impedance at electrode-skin interface. According to the test results, if without active dry electrodes, the CMRR of the front-end circuit is only 42.7dB, while the CMRR of the front-end circuit with active dry electrodes is 44.8dB.

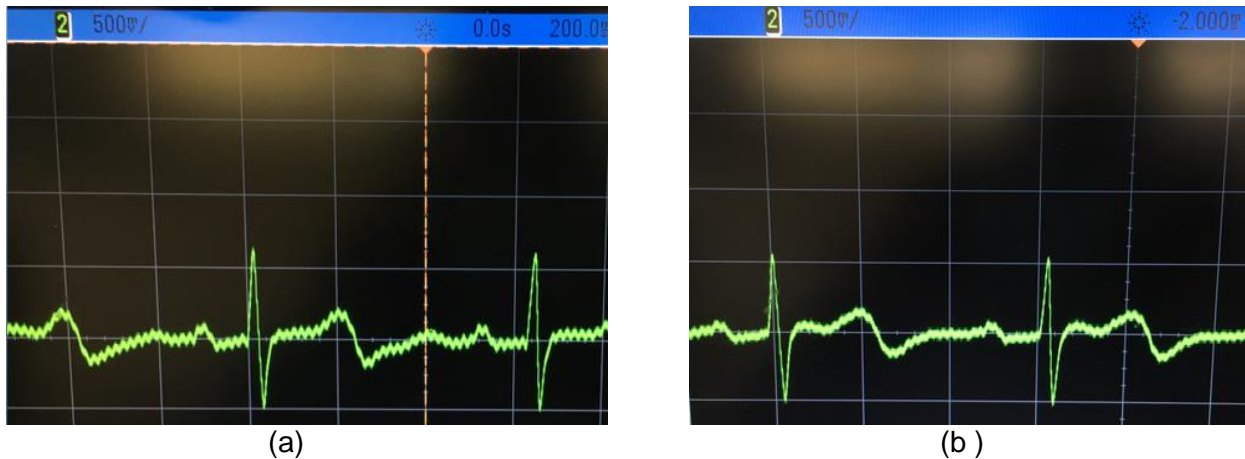

Figure 4.16: (a) human ECG recorded with simple dry electrodes; (b) human ECG recorded with active dry electrodes has less noise.

4.2 System Field Test

The field test is approved by Institutional Animal Care and Use Committee (protocol number 16-17 #122). All 5 recruited test subjects in this test were off-campus and privately owned pet dogs.

Before the test, no preparation was needed for the dogs at all, the hair of the dogs was not shaved nor brushed. During the test, electrode LA, RA and RL were respectively placed on dogs' unbroken skin of left front leg, right front leg and right rear leg, as shown in Fig.4.2. Elastic bands on the electrodes kept the electrodes well attached on the dogs' skin. The dog owner kept the dog calm and seated while the dog's ECG data was recorded.

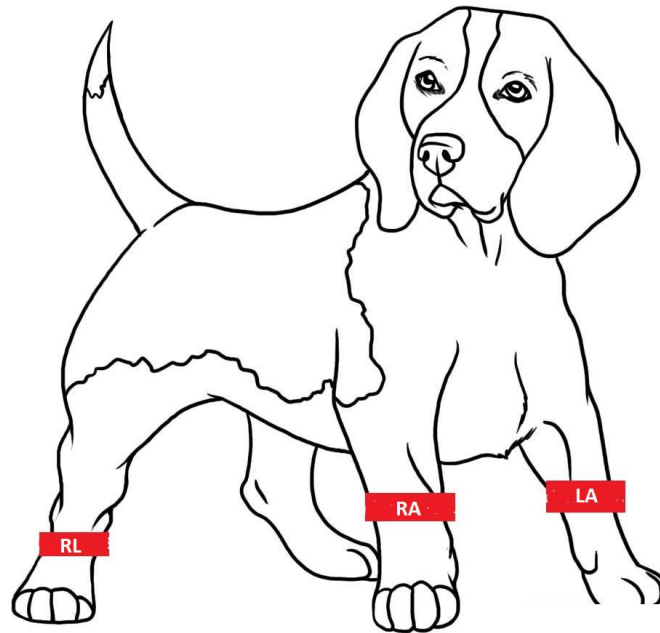

Figure 4.2: electrodes placement

During the field test, 5 dogs' ECG data were collected with the prototype of this proposed ECG monitor, the result of data analysis is shown in Table 1 and Table 2. It is obvious to see that Dog 1 and Dog 2 has a higher average heart rate. All 4 of them are medium or large sized dogs, but Dog 1 and Dog 2's average heart rates are above 90bpm, while the other 2 are below 90bpm. Also, Dog 1 and Dog 2 has a much higher standard deviation, almost 2 times of the standard deviation of the other 2. It's because Dog 1 was walking, and Dog 2 just had a swim before they were tested, and they were both excited and confused by the test, especially Dog 2. And that is why Dog 2 had the highest HR among them all. On the other hand, Dog 3 and Dog 4 had lower heart rates because their ECG tests took place in a backyard, and their owner, Mick, held them,

and kept them relaxed and seated when their ECG were recorded. However, Dog 5's test result is out of expectation. Dog 5 is a pug, as a small sized dog, her heart rate is lower than normal range. She could have bradycardia, but the monitor didn't display any warning because Dog 5's heart rate range is still within the diagnosis functions' normal range.

Table 1, Heart rates of the 5 dogs

Name/Data	Body size	HR mean \pm SD	HR min~max	Dog's status
Dog 1	Large	91.9 \pm 22.5 bpm	70~144 bpm	excited, walking
Dog 2	Medium	98.2 \pm 20.5 bpm	73~137 bpm	swam, excited
Dog 3	Large	86.7 \pm 10.4 bpm	72~105 bpm	calm, sitting
Dog 4	Large	84.7 \pm 7.6 bpm	72~102 bpm	calm, sitting
Dog 5	Small	73.2 \pm 11.2 bpm	63~104 bpm	walking

Data from Table 2 suggests that compared to other 4 dogs, Dog 2, the most excited and energetic dog, had the highest bottom value of Vm range (0.41mV), that is, the range of maximum amplitude of ECG. Also, the reason that Dog 1 and Dog 2's heartbeats look a bit less stronger than Dog 3 and Dog 4's is that Dog 1 and Dog 2 were both excited during the test, they both had a higher heart rate. On the other hand, Dog 3 and Dog 4 were calm, their bodies needed less oxygen and energy, so that their heartbeats were relatively slower and each heartbeat was more efficient, namely, stronger. This phenomenon is also found in athletes - because of training, athletes commonly have stronger and more efficient hearts, and their heart rates are usually below 70bpm, lower than most people.

Table 2, Strength of heartbeats of the 5 dogs

Name/Data	Body size	Vm mean \pm SD	Vm min~max	Dog's status
Dog 1	Large	0.51 \pm 0.19 mV	0.27~0.89 mV	excited, walking
Dog 2	Medium	0.55 \pm 0.20 mV	0.41~1.09 mV	swam, excited
Dog 3	Large	0.58 \pm 0.26 mV	0.22~0.86 mV	calm, sitting
Dog 4	Large	0.59 \pm 0.24 mV	0.31~0.98 mV	calm, sitting
Dog 5	Small	0.40 \pm 0.10 mV	0.23~0.55 mV	sitting

CHAPTER V: Conclusion

The data analysis in Chapter 4 shows that the prototype of this proposed ECG monitor for dogs is capable of monitoring dog's heart status. It is able to monitor the change of heart rate and the strength of heartbeat from a dog. The whole system operates on batteries, therefore it has achieved goal to be portable, and the active dry electrodes has made this device more convenient for long-term monitoring.

One more thing that worth mentioning is that, to find out its accuracy, I have used this monitor to test myself. My actual heart rate is around 82~86bpm, and the result from the monitor indicated 83.2 ± 3.9 bpm. Also, according to the results from oscilloscope during the front-end test (Fig.4.1), the V_m of my heartbeat is approximately 0.45mV. And the monitor indicated that my V_m is 0.42 ± 0.08 mV. These results have shown that the prototype of the proposed design is accurate. However, after the field test, it is also found to have plenty of space to upgrade and refine the design.

In hardware, the monitor could use 3 metal clips with wireless modules to replace current dry electrodes. Because during the field test, the electrodes have inconvenient wires and sometimes it had Dog 2 attaching to dog's body tightly. If the electrodes are designed to be clips instead of metal plates, it would greatly help in this situation. Also, as shown in Fig.4.1, the output of front-end circuit still contains a tiny amount of 60Hz noise. It is likely acquired and amplified at the second stage of circuit, which is at OP07CP amplifier. An isolation cloak around the whole circuit should further reduce the noise. Moreover, the circuit could add a buzzer to send out different sound of alarms when different abnormal heart conditions are detected.

In software, the algorithm of heart rate calculation can be upgraded by precisely detecting the peak of R wave using pattern recognition. And the parameters in diagnosis functions need to be calibrated with veterinary personnel.

REFERENCES

1. American Veterinary Medical Association, U.S. Pet Ownership & Demographics Sourcebook 2012 Edition, American Veterinary Medical Association, 2012.
2. Jaakko Malmivuo & Robert Plonsey, Bioelectromagnetism - Principles and Applications of Bioelectric and Biomagnetic Fields, Oxford University Press, 1995, Chap 6.2.1.
3. Valerica Raicu and Aurel Popescu, Integrated Molecular and Cellular Biohysics, Springer Science, 2008, page 147~164.
4. Kai Li, Xiafei Zhao, Progress of Research on Dog's Normal ECG, Journal of Chinese Veterinary Medicine, 2001, 37(12):38-40.
5. Xiaoyang Zhang, Zhe Zhang, Yongfu Li, A 2.89 μ W Dry-Electrode Enabled Clockless Wireless ECG SoC for Wearable Applications, IEEE Journal of Solid-State Circuits, 2016.
6. Tai Le, Huy-Dung Han, Thai-Hoc Hoang, A Low Cost Mobile ECG Monitoring Device Using Two Active Dry Electrodes, Communications and Electronics (ICCE), July 2016.
7. Jun Han, Yicheng Zhang, An Area-Efficient Error-Resilient Ultralow-Power Subthreshold ECG Processor, IEEE Transactions on Circuits and Systems, Oct. 2016.
8. Awadhesh Pachauri, A New Approach to ECG Peak Detection, Research Gate, 29 April 2017.
9. Donati M., Benini A., Celli A., Iacopetti F., A Novel Device for Self-acquisition of ECG Signal in Telemedicine Systems for Chronic Patients, Computers and Communication (ISCC), June 2016
10. James J. Bailey, Alan S. Berson, Recommendations for Standardization and Specifications in Automated Electrocardiography: Bandwidth and Digital Signal Processing, Circulation, February 1990.
11. John G. Proakis, Digital Signal Processing 4th Edition, Thomson Press Ltd., 2007, page 582~594, page 701~727.

Appendix A

Schematics of front-end circuit and the proposed prototype monitor.

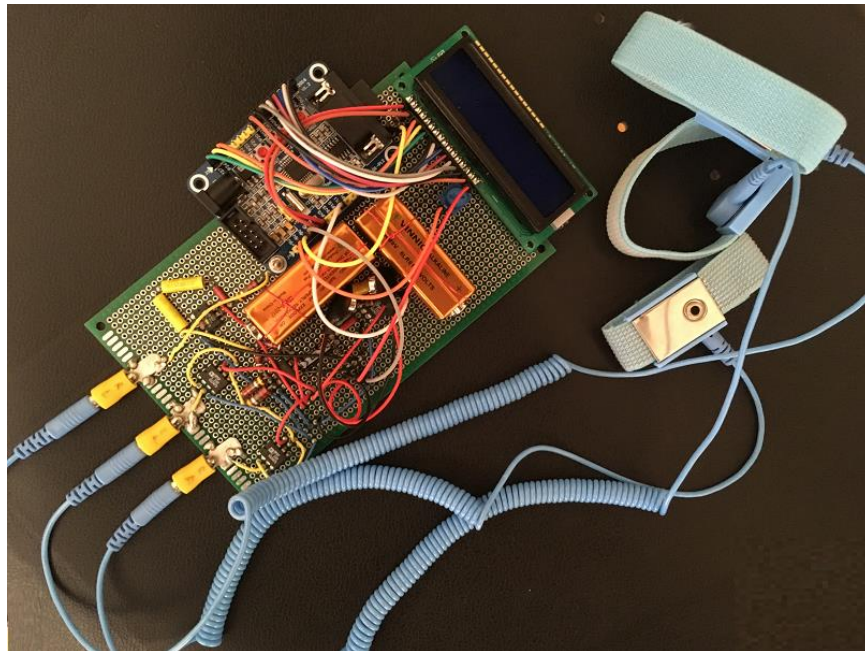
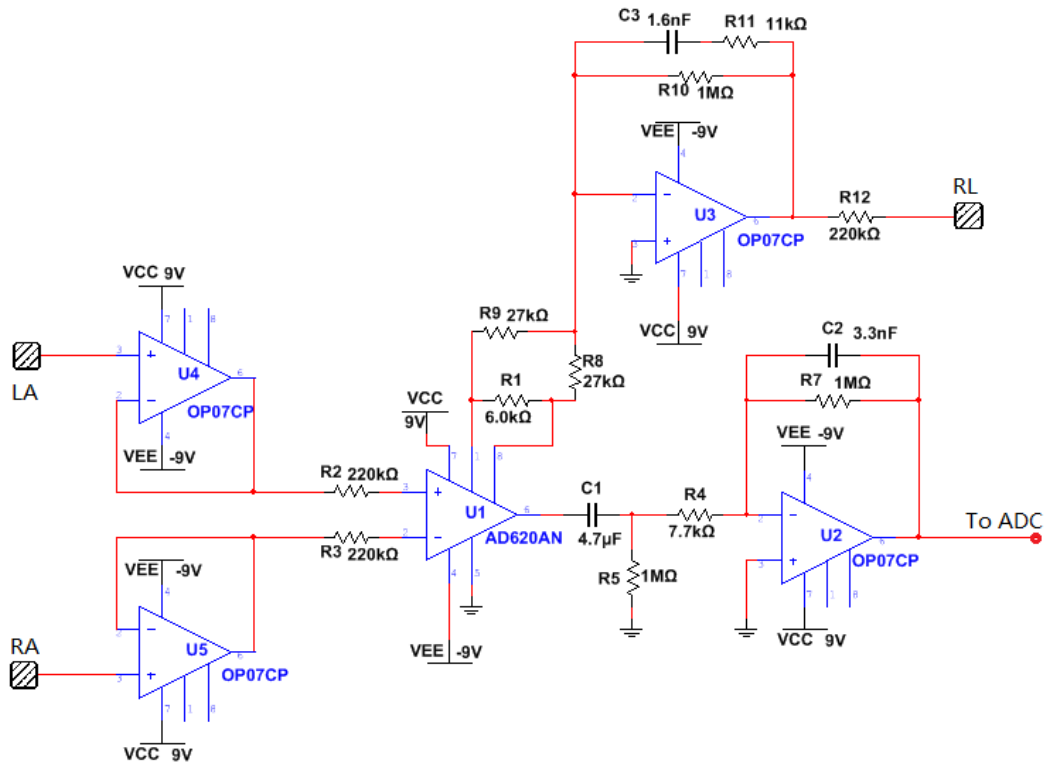

Appendix B

Raw data of HR of the 5 dogs (bpm).

Dog 1	Dog 2	Dog 3	Dog 4	Dog 5
73	84	86	84	64
79	92	86	72	90
90	92	92	92	64
73	92	76	84	63
76	86	86	102	64
115	137	105	84	88
72	125	76	90	104
86	125	96	84	90
106	90	92	86	66
77	73	81	86	75
77	73	96	84	64
73	92	98	76	63
115	115	86	84	66
92		72	90	68
137		73	75	63
70		73	98	66
144		79	90	68
		102	84	64
		72	84	66
		98	76	78
		86	98	64
		96	76	82
			84	84
			84	73
			72	69
			79	90
			90	73
				81

Appendix C

Raw data of Vm of the 5 dogs (mV).

Dog 1	Dog 2	Dog 3	Dog 4	Dog 5
0.89	0.46	0.27	0.41	0.38
0.34	0.79	0.79	0.41	0.54
0.35	0.46	0.73	0.59	0.38
0.28	1.09	0.73	0.98	0.32
0.27	0.47	0.37	0.61	0.34
0.61	0.41	0.37	0.31	0.38
0.62	0.45	0.86	0.91	0.41
0.45	0.41	0.22	0.47	0.55
0.43	0.62	0.86		0.36
0.52	0.47			0.52
0.72	0.49			0.24
0.58	0.50			